

ORCA™ MODEL OG50

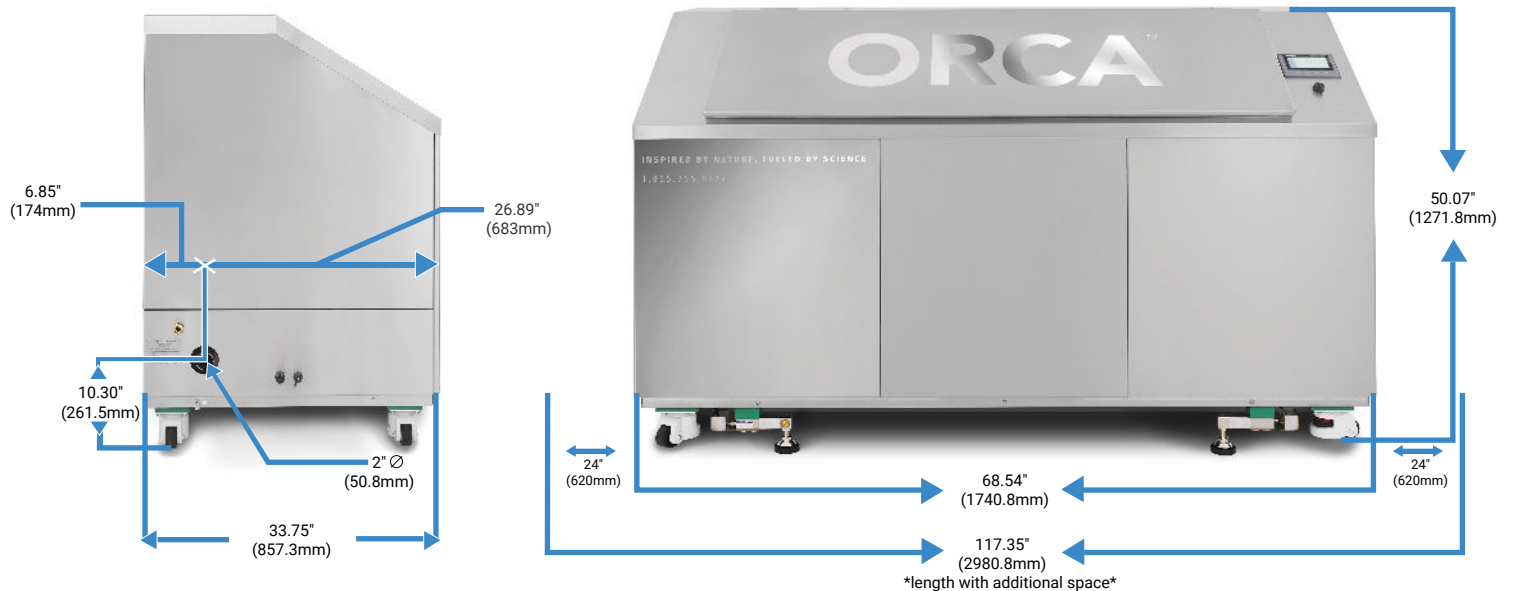

MODEL OG50 SPECIFICATIONS

REQUIRED SUPPLIES ORCA Biochips, microorganisms & wipers	DIMENSIONS L 68.54" x W 33.75" x H 50.07" (L 175 cm x W 86 cm x H 127 cm)
WEIGHT 1400 lbs (635 kg)	HOURLY PROCESSING CAPACITY Average of 50 lbs (23 kg) per hour
ELECTRICAL CONSUMPTION 1.2 kWh	WATER CONSUMPTION 114 gallons (430 litres) per day *Calculated based on an incoming flow rate of 2 gallons (7.6 litres) per minute*
INSTALLATION REQUIREMENTS Electrical - Dedicated 120V / 220V Electrical Cord Length - 36 - 48 inches (91 - 121 cm) Water - Cold 1/2 inch (1.3 cm) water connection Drain - Min. 2 inch (5.08 cm) sanitary drain complete with grease interceptor Additional Space - A minimum of 24 inches (62 cm) of free space must be available on both sides of the machine for maintenance	

FEATURES

- Aerobically processes an average of 50 lbs (23 kg) of food waste per hour
- On-board scales for diversion tracking, with an extractable data file through ethernet or USB
- Online customer portal for diversion goal tracking and reporting
- Food waste can be added continuously until maximum capacity is reached
- Safety control turns off the machine when door is opened
- Engineered for quiet operation, with a touch screen HMI
- 1 hp electric motor
- Utilizes ORCA Biochips to hold high levels of microorganisms that digest organic waste
- Effluent from machine tested safe to enter the wastewater system
- Food-grade stainless steel construction



ORCA™ MODEL OG50

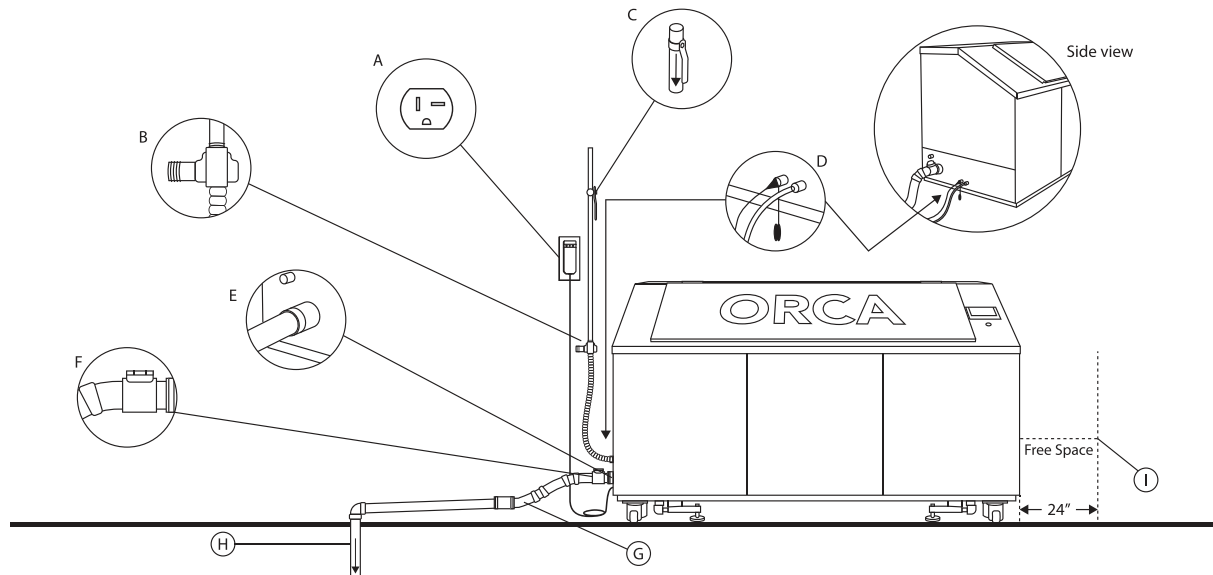

- A** – Dedicated 120v or 220v outlet on a dedicated breaker
- B** – ½ inch (1.3 cm) cold waterline connected to the provided flex line via a garden hose fitting
- C** – Water shutoff valve connected to the cold-water line upstream from the ORCA
- D** – WIFI or ethernet connection
- E** – Drain line that is compatible with the ORCA's 2" (5.08 cm) exit pipe
- F** – Plumbing cleanout approximately 5" (13 cm) from the ORCA
- G** – Direct drain line with a slope of ½" per 12" (1.3 cm per 30 cm) downstream of the ORCA
Avoid the use of P-traps
- H** – Downstream above or below-ground grease interceptor
- I** – 24" (62 cm) of free space on both sides of the ORCA

DISCLAIMER

ORCA staff and technicians are not responsible for the installation or maintenance of the facility's plumbing, electrical or IT requirements